

BLD72, BLD72-1 Bilevel Step Motor Driver

User's Guide

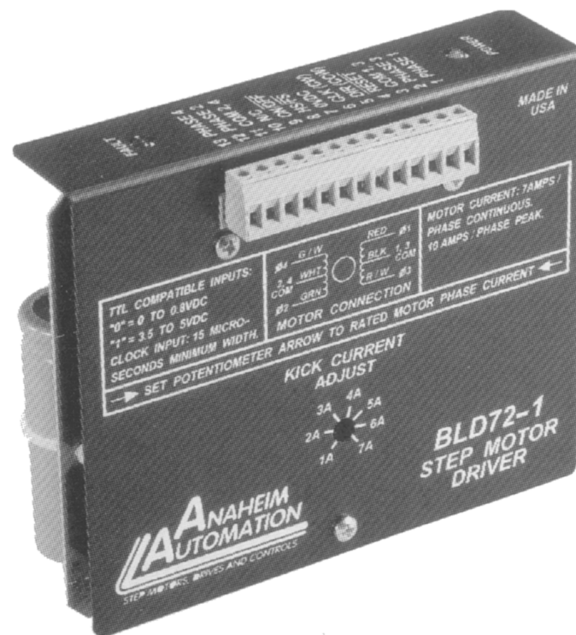

ANAHEIM AUTOMATION

910 East Orangefair Lane, Anaheim, CA 92801
e-mail: info@anaheimautomation.com

(714) 992-6990 fax: (714) 992-0471
website: www.anaheimautomation.com

Features

- Bilevel Driver Operation
- 10 Amps per Phase Operating Current (Kick Current)
- 7 Amps per Phase Standstill Current
- 70 Volt Operation
- Short Circuit Protection
- Open Circuit Protection
- Unipolar Operation
- Motor ON/OFF Input
- Half-Step and Full-Step Operations
- Fault LED
- Detachable Terminal Block
- CE Certified
- Compact and Rugged
- **Available in Driver Packs**

What Is a Step Motor Driver?

A step motor driver is a device that takes input signals (usually Clock and Direction) and translates this information into phase currents in the motor. Each time the step motor driver receives a pulse, the step motor moves one step. If the driver receives 200 pulses, the motor moves 200 steps. The motor steps at the same frequency as the clock pulses.

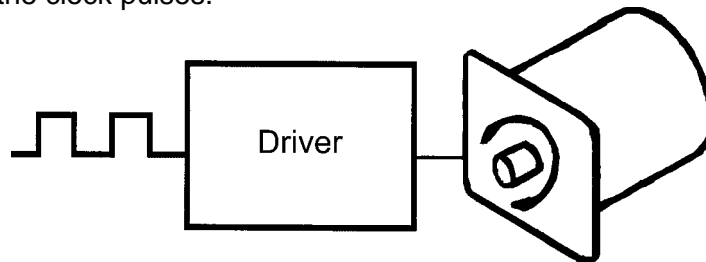

FIGURE 1: Step Motor Driver

General Description

The BLD72 is a step motor driver that can drive motors rated from 1 to 7 amps/phase (unipolar rating). It can handle 6 lead and 8 lead motors. This driver features a unipolar bilevel (or dual voltage) drive technique with short and open circuit protection (with a Fault LED). A transformer is required to power up the driver.

Bilevel Drive

The basic function of a motor driver is to provide the rated motor phase current to the motor windings in the shortest possible time. The bilevel driver uses a high voltage to get a rapid rate of current rise in the motor windings in the least amount of time. When reaching the preset trip current, the driver turns off the high voltage and sustains the current from the low voltage supply.

Half-Step/Full-Step

Users have a choice of full-step operation or half-step operation. Full-step operation occurs by energizing two phases at a time, rotating a typical motor 1.8 degrees per step. Half-step operation occurs by alternately energizing one, and then two, phases at a time, rotating the motor 0.9 degrees per step. Full-step operation is suggested for applications that specifically require that mode, such as when retrofitting existing full-step systems.

Clock Modes

The BLD72 has two clock options: Clock and Direction, or Dual Clock operation. Jumper JP2 is used to select the clock option. Basically JP2 selects Terminal 5 as either the Direction input or the CCW input.

With the Clock and Direction option (most common option), clock pulses applied to the Clock input (Terminal 6) cause the motor to step. The direction of the motor is determined by the logic level of the Direction input (Terminal 5). Jumper JP2 must be in the “2-3” position for this mode (see Figure 4 and Table 1). Physical direction also depends on the motor wiring.

With the Dual Clock option, clock pulses applied to the Clock input (Terminal 6) cause the motor to step in the clockwise direction. Clock pulses applied to the CCW input (Terminal 5) cause the motor to step in the counterclockwise direction. Jumper JP2 must be in the “1-2” position for this mode.

Either positive or negative going pulses may be used by setting jumpers in the appropriate position (see Table 1). To determine which setting to use, first consider the type of clock pulse output on the pulse generator or indexer (controller). If the clock output on the controller is open-collector type (sinking), then use the negative going jumper setting. If the clock output on the controller is a pnp or p-channel (sourcing) type, then use the positive going jumper setting. If the clock output on the controller is a TTL/CMOS type (totem pole), then either setting will work; but the jumper setting should be chosen based on the level of the clock output when the controller is not pulsing. If the clock is low when not pulsing, then use positive going jumper settings. If the clock is high when not pulsing, then use the negative going jumper setting.

The clock inputs (Clock and CCW) are pulled up to +5Vdc through a 10K ohm resistor for negative going clock inputs; or pulled down to 0VDC through a 10K ohm resistor for positive going clock inputs. The pullups/pulldowns are followed by an RC filter. See Figure 2 and Figure 3.

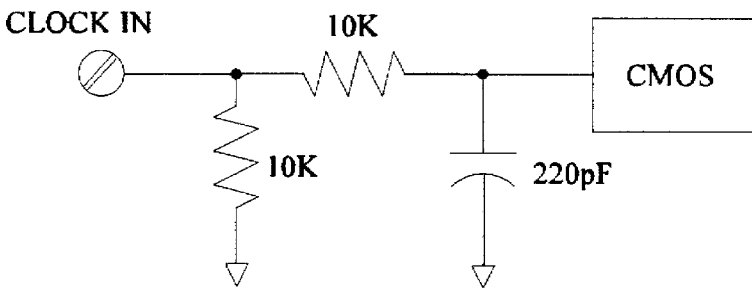

Figure 2: Sourcing Clock Input

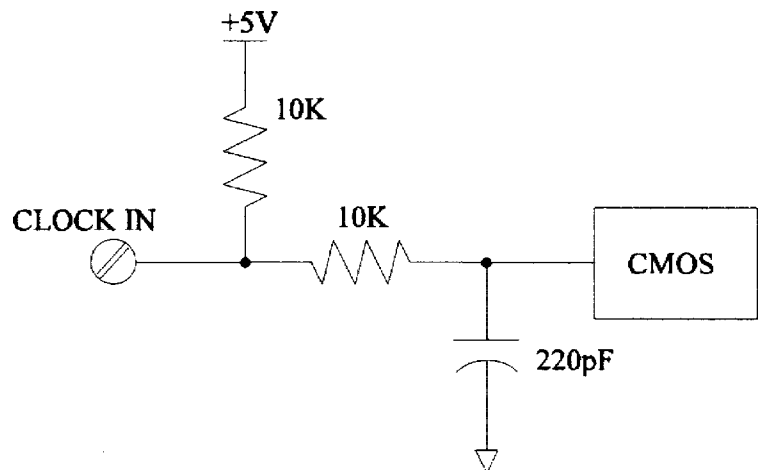

Figure 3: Sinking Clock Input

Motor On/Off Input

The motor on/off input allows de-energizing a motor without disturbing the positioning logic. After reenergizing the motor, a routine can continue. This reduces motor heating and conserves power, especially in applications where motors are stopped for long periods and no holding torque is required. If holding torque is required (such as when lifting a load vertically), then the motor must stay energized.

Jumper Functions/Locations

| Function | JP1 | JP2 | JP3 |
|---------------------------------|-----|-----|-----|
| Negative Going Clocks | 1-2 | X | X |
| Positive Going Clocks | 2-3 | X | X |
| Terminal 5 = CCW | X | 1-2 | X |
| Terminal 5 = Direction | X | 2-3 | X |
| Ground Fault Detection Enabled | X | X | 2-3 |
| Ground Fault Detection Disabled | X | X | 1-2 |
| Standard Product | 1-2 | 2-3 | 2-3 |

Table1: Jumper Settings

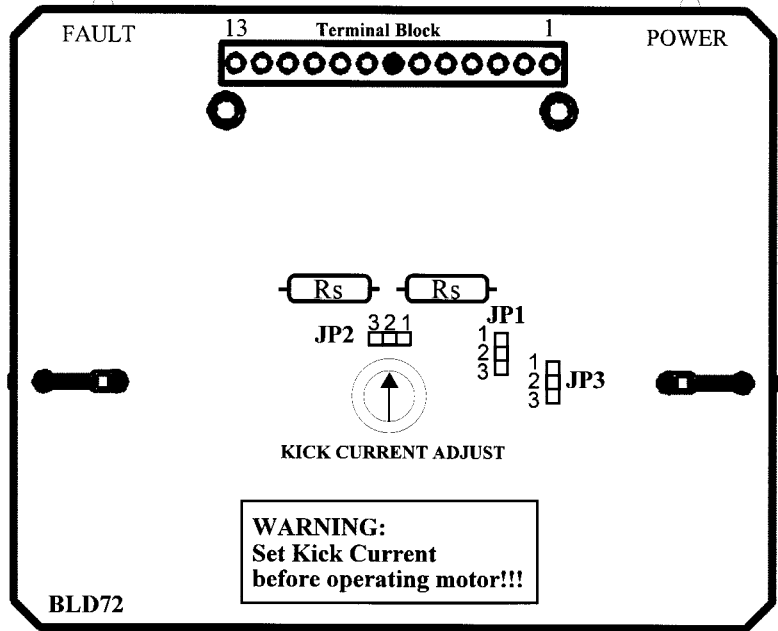
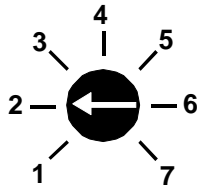

Figure 4: Layout Drawing

Adjusting Kick Current

By following the instructions on the cover, use a small screwdriver to adjust the potentiometer. Line up the potentiometer's arrow to the number corresponding to the motors rated current (amps/phase).



Example 1: 23D104 Motor, Set to 2.0A.

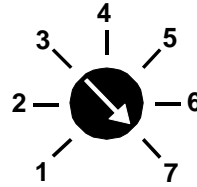

Example 2: 34D314 Motor, Set to 7.0A.

Fault Protection

There are 3 types of fault detection. When a fault is detected, the driver turns off the motor current and the red Fault LED indicates which type of fault occurred. See the Troubleshooting section for more information.

| | | |
|---|------------------|---------------------------------------|
| 1 | LED - Slow Blink | Shorted wire in the motor or cable. |
| 2 | LED - Fast Blink | Open wire in the motor or cable. |
| 3 | LED - ON Steady | Ground fault (voltage shorted to 0V). |

Table 2: LED Blink Definitions

If the driver goes into a fault condition, the fault may be reset by turning the power OFF for at least 15 seconds or by pulling the RESET FAULT input (terminal 4) to a logic "0" for at least 100ms.

Motor Connections

Figure 5 is a hookup diagram for typical BLD72 driver applications. *Wiring connected to inputs must be separated from motor connections and all other possible sources of interference.*

IMPORTANT NOTE: When the wiring from the driver to the step motor extends beyond 25 feet, consult the factory.

Wiring Diagram

The wiring diagram in Figure 5 shows the BLD72 with the AA2791 Transformer. For wiring with the AA2793 Transformer, refer to Figure 9.

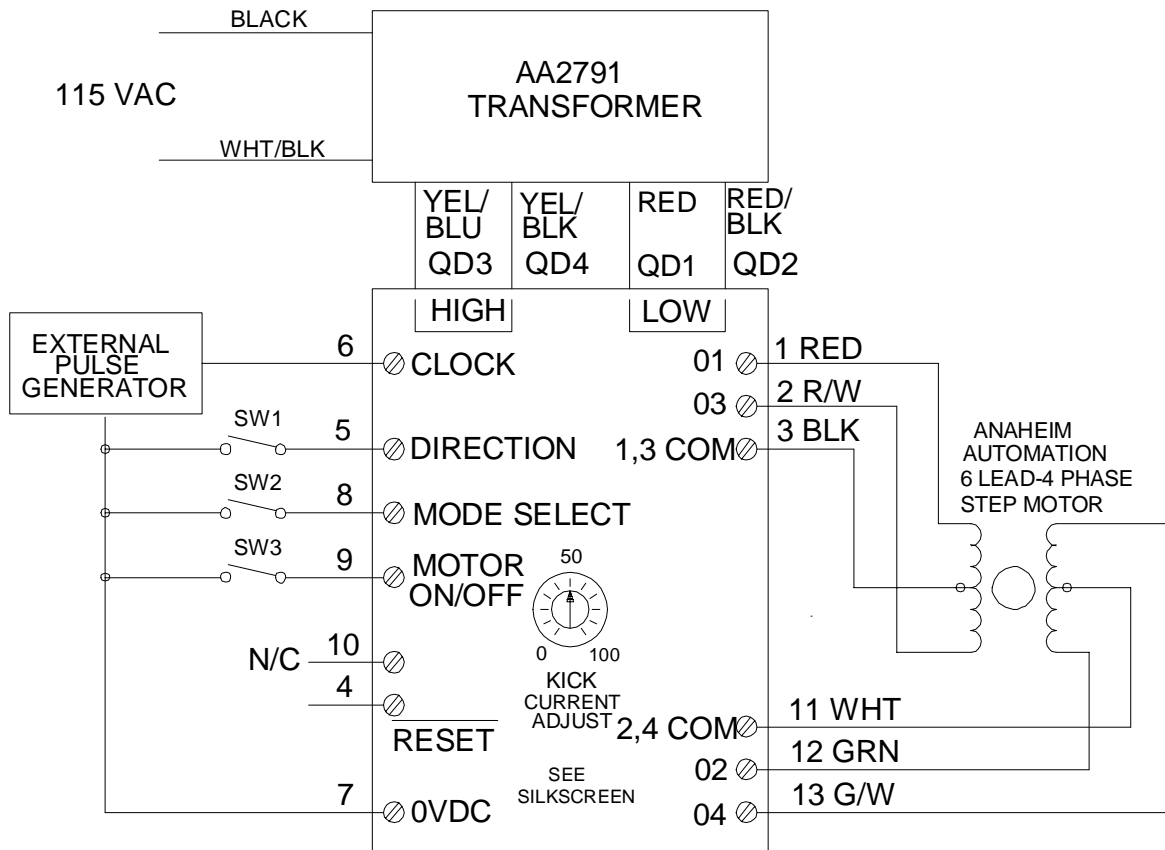

Figure 5: Hook Up Drawing

Power Supply Requirements

The BLD72 must be powered by a recommended Anaheim Automation transformer. The AA2791 transformer and the AA2793 transformer are the most commonly used and are both rated for 300VA. These transformers have a high voltage winding, a low voltage winding, and a logic voltage winding. The AA2793 has two high voltage windings and two low voltage windings for powering two BLD72's. The high voltage winding (yellow) and low voltage winding (red) plug into the quick disconnects on the back of the BLD72 (see hookup diagram in Figure 5). The logic voltage winding (orange) is used to power up optional controllers. When using one of these transformers, the nominal low-voltage is 5.0 volts and the nominal high-voltage is 60V. The transformer voltages are shown in Figures 7 and 8; the physical dimensions are shown in Figure 6. For other transformers, contact the factory.

Transformer Drawings

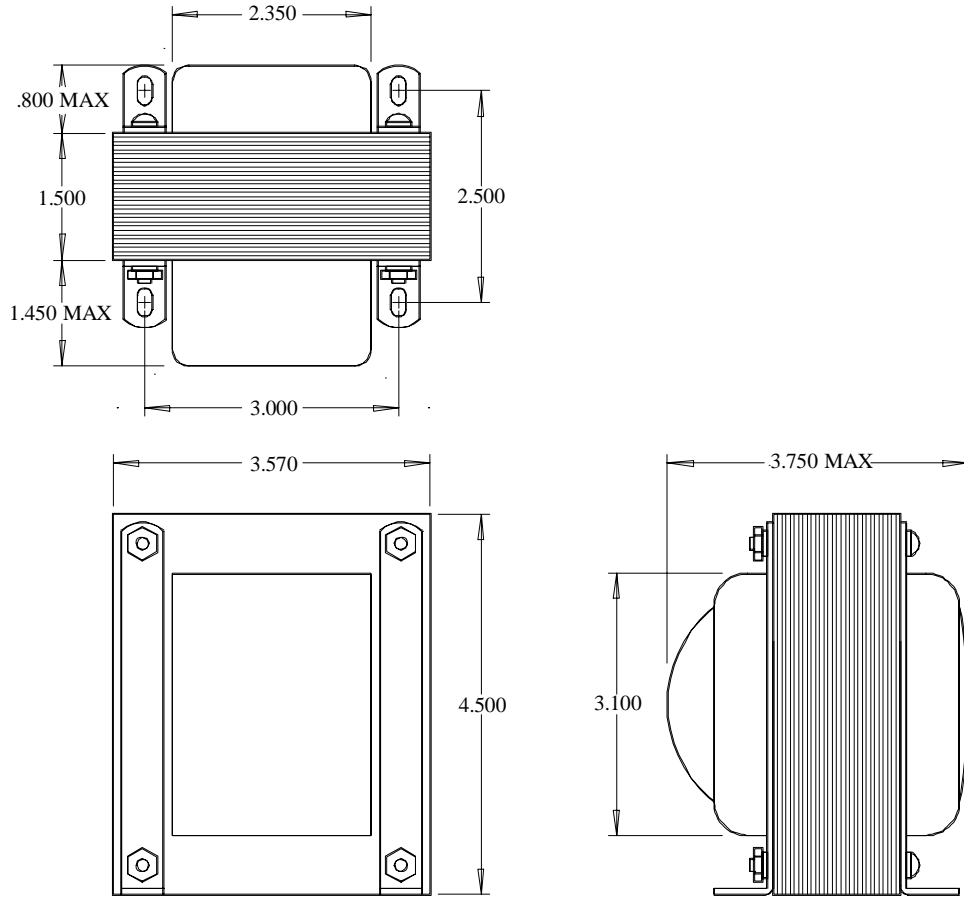

Figure 6: Transformer Dimensions

Note: The AA2793 transformer is the same physical size as the AA2791, but it has two sets of secondary windings (to power two drivers) and a dual primary winding for 115/230V operation.

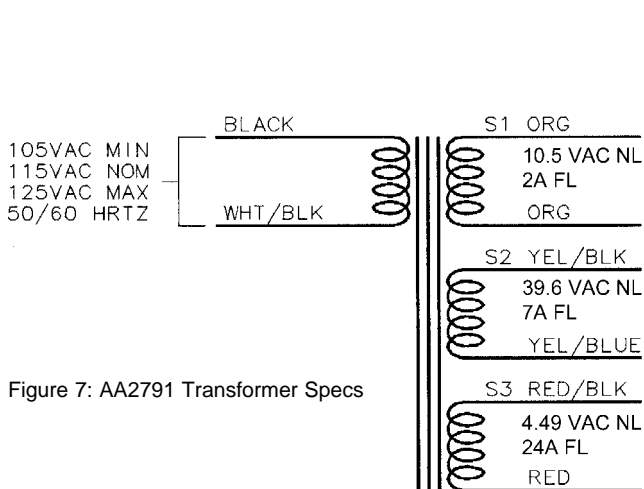

Figure 7: AA2791 Transformer Specs

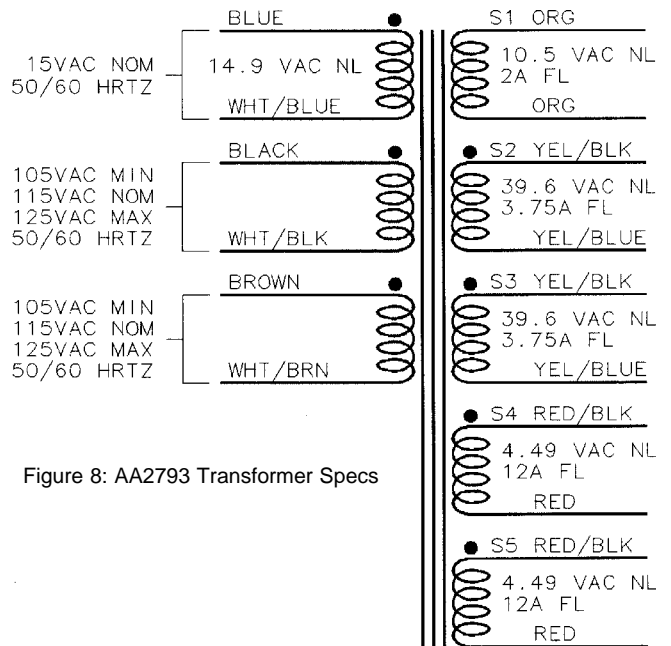

Figure 8: AA2793 Transformer Specs

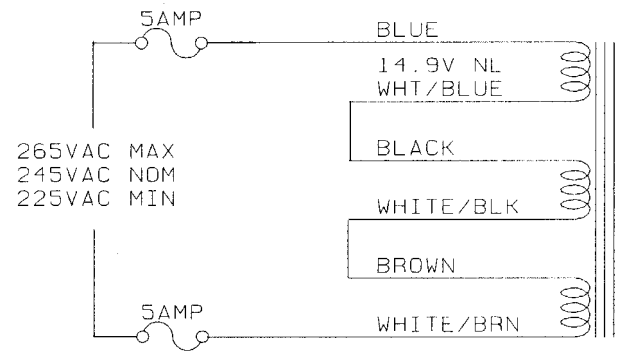
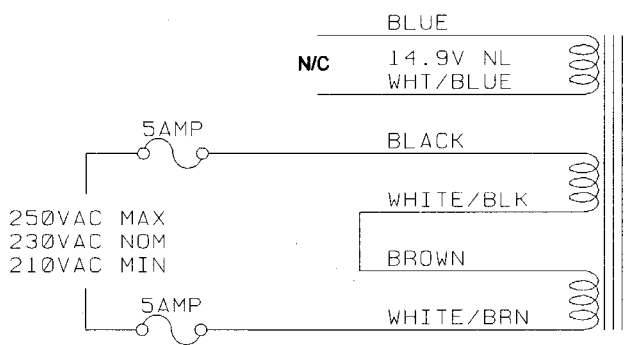
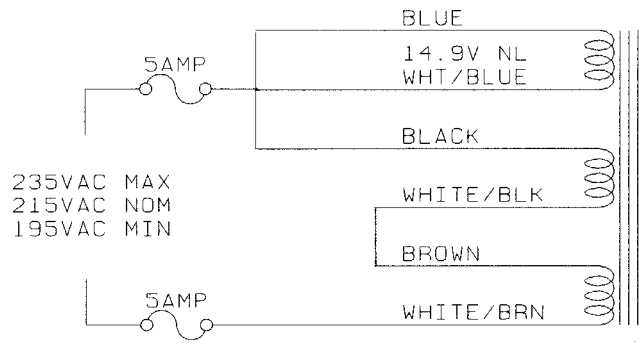
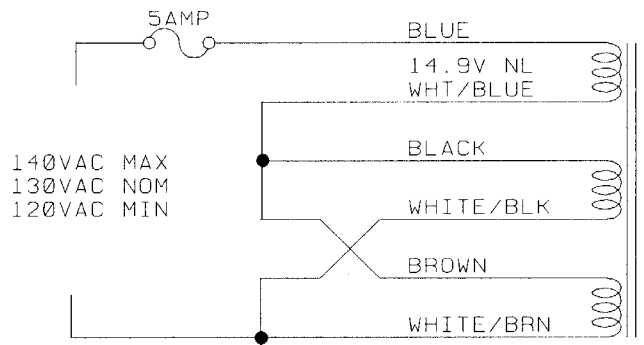
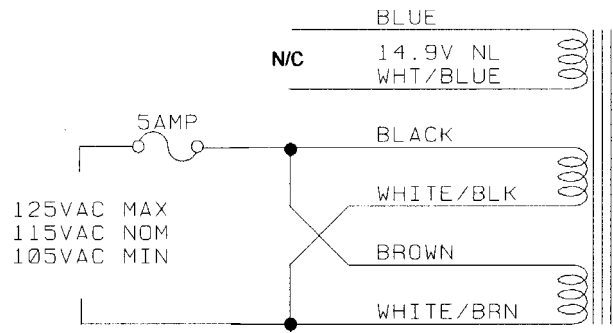
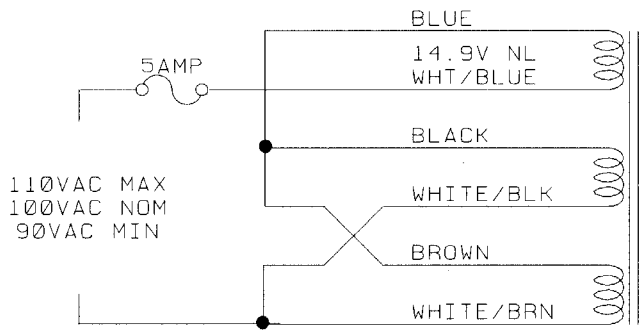

Figure 9: Wiring for different line voltages for the AA2793 transformer.

Dimensions Drawings

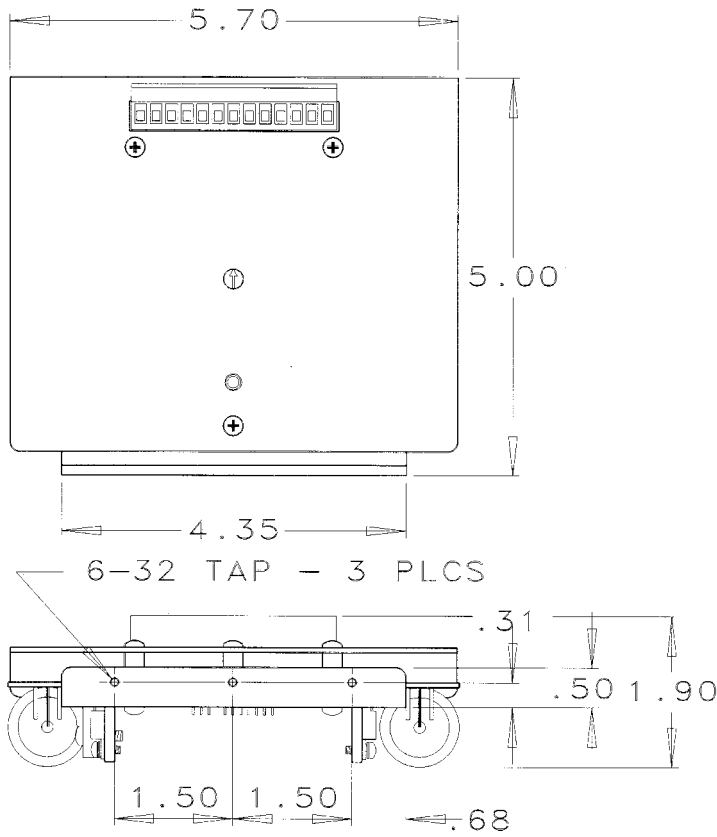

Figure 10: BLD72 Dimensions

Note: The BLD72 and BLD72-1 are the same except for the base plate. The BLD72 is a replacement driver for use in Driver Packs. The BLD72-1 is a modular driver which has a larger base plate.

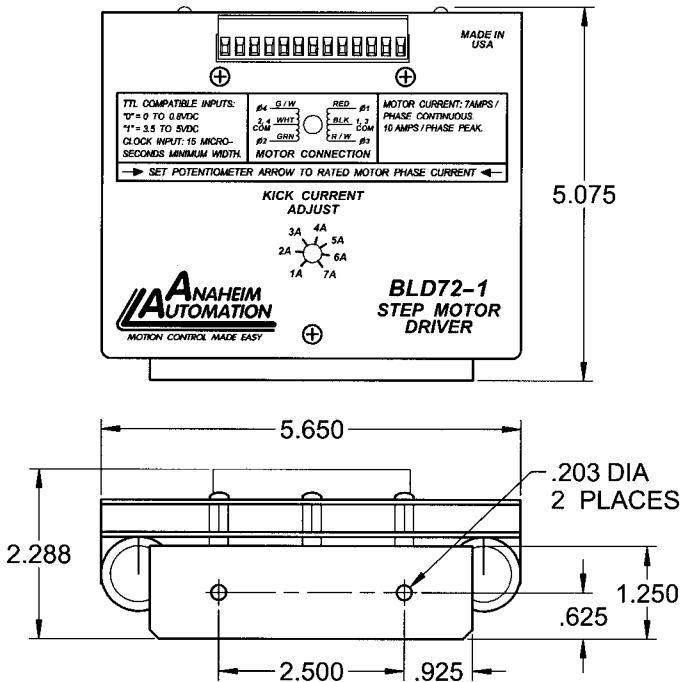

Figure 11: BLD72-1 Dimensions

13 Pin Terminal Description

| Terminal # | Description |
|------------|---------------------|
| 1 | Motor, Phase 1 |
| 2 | Motor, Phase 3 |
| 3 | Motor, Common 1, 3 |
| 4 | Fault Reset |
| 5 | Direction (CCW) |
| 6 | Clock (CW) |
| 7 | 0VDC |
| 8 | Half-Step/Full Step |
| 9 | On/Off |
| 10 | N/C |
| 11 | Motor, Common 2, 4 |
| 12 | Motor, Phase 2 |
| 13 | Motor, Phase 4 |

Motor Compatibility

Standard Motors

| Part # | Unipolar Rating |
|---------|-----------------|
| 23D104_ | 2.0A |
| 23D108_ | 4.0A |
| 23D209_ | 4.5A |
| 23D309_ | 4.5A |
| 34D106_ | 3.0A |
| 34D109_ | 4.5A |
| 34D207_ | 3.5A |
| 34D213_ | 6.5A |
| 34D314_ | 7.0A |
| 42D112_ | 6.0A |
| 42D212_ | 6.0A |

High Torque Motors

| Part # | Unipolar Rating |
|---------|-----------------|
| 23L206_ | 3.0A |
| 23L210_ | 5.0A |
| 23L306_ | 3.0A |
| 23L310_ | 5.0A |
| 34N108_ | 4.0A |
| 34N112_ | 6.0A |
| 34N207_ | 3.5A |
| 34N214_ | 7.0A |
| 34N307_ | 3.5A |
| 34N314_ | 7.0A |
| 42N115_ | 7.5A |

Add suffix "S" for single-ended shaft, or suffix "D" for double-ended shaft.

Notes: Other motors not listed above may be compatible with this driver.

Anaheim Automation carries a full-line of standard and high torque step motors. Contact the factory regarding compatibility. See back cover for speed/toque curves.

Specifications

Control Inputs (All) : (Terminals 5, 6, 8, 9)

TTL-compatible

Logic "0" - 0 to 0.8 V

Logic "1" - 3.5 to 5.0 V

Fault Reset: (Terminal 4)

Pulled up to +5VDC through a 10k Ohm resistor

Logic "1" (open) - Driver enabled and Fault detection enabled

Logic "0" - Resets a Fault condition (driver is disabled when this input is low). This input must be held low for at least 100ms.

Clock Inputs : (Terminals 5 and 6)

Pulse required; 15 microseconds minimum. The clock input is pulled up/down internally to +5VDC / 0VDC through a 10k Ohm resistor, based upon JP2 selection.

Direction Control: (Terminal 5)

Pulled up to +5Vdc through a 10k Ohm resistor

Logic "1" (open) - CW

Logic "0" - CCW

Excitation Mode Select: (Terminal 8)

Pulled up to +5Vdc through a 10k Ohm resistor

Logic "1" (open) - Half-step

Logic "0" - Full-step

Power ON/OFF: (Terminal 9)

Logic "1" (open) - motor current on

Logic "0" - motor current off

Output Current Rating:

(Terminals 1, 2, 3, 11, 12, and 13)

10 Amps/phase maximum operating current, 7.0 Amps/phase maximum standstill current, over the operating voltage and temperature range. Motor phase ratings of 1.0 Amp minimum are required to meet the minimum kick level.

Power Requirement:

Anaheim Automation recommended transformer.

Operating Temperature : 0 to 60 degrees C

It is recommended that the aluminum driver baseplate be mounted on a larger aluminum plate, or similar heat-conducting structure, whenever possible. This will prevent the driver baseplate from overheating and degrading driver reliability. **Fan cooling is also recommended whenever possible.**

FUSING: A 5 Amp Fast Blow fuse in series with the primary winding of the transformer is required.

Troubleshooting

If a Fault occurs, reset the Fault by applying a logic “0” to the Reset Fault Input (terminal 4) for at least 100ms (or by cycling power OFF for at least 15 seconds). After resetting, try to run the motor again. If the driver faults again then check the conditions listed below.

Is the LED blinking slowly? (Once a second)

This indicates that the motor has a phase shorted or there is a short in the motor cable or wiring. Check the motor and the wiring for shorts. If the driver continues to sense “shorts” after the motor and wiring are determined to be accurate, then the output transistors should be checked (see below).

Is the LED blinking quickly? (Three times a second)

This indicates that there is an open or intermittent connection in one of the motor wires. Check the motor and the wiring for opens. Another condition that may cause this type of fault, is when a large motor is ramped down too quickly so that it loses its positioning.

Is the LED on steadily?

This indicates that there is a ground fault - a voltage shorted to 0V. This detection is useful in detecting a short-to-case in a motor when the motor’s case AND the driver’s 0V are both connected to earth ground. Excessive noise on the 0V line may also cause the driver to sense this type of fault. This type of fault sensing may be disabled by placing jumper JP3 in position “1-2”. NOTE: If the ground fault detection is disabled, DO NOT connect the driver’s 0V to earth ground!

Checking Output Transistors

1. Remove the side plate
2. Set the multimeter to Diode Test
3. Place the RED meter lead on (between) the Sense Resistors (labeled as “R”s in Figure 4)
4. Touch the black meter lead to each phase (terminals 1, 2, 12, and 13)
5. Reading should be between 0.450V and 0.550V
6. If any readings are significantly less than 0.450V, then the unit has been damaged.

If a factory repair is required, contact Anaheim Automations for an RMA#.

(800) 345-9401 or (714) 992-6990

COPYRIGHT

Copyright 2001 by Anaheim Automation. All rights reserved. No part of this publication may be reproduced, transmitted, transcribed, stored in a retrieval system, or translated into any language, in any form or by any means, electronic, mechanical, magnetic, optical, chemical, manual, or otherwise, without the prior written permission of Anaheim Automation, 910 E. Orangefair Lane, Anaheim, CA 92801.

DISCLAIMER

Though every effort has been made to supply complete and accurate information in this manual, the contents are subject to change without notice or obligation to inform the buyer. **In no event will Anaheim Automation be liable for direct, indirect, special, incidental, or consequential damages arising out of the use or inability to use the product or documentation.**

Anaheim Automation’s general policy does not recommend the use of its’ products in life support applications wherein a failure or malfunction of the product may directly threaten life or injury. Per Anaheim Automation’s Terms and Conditions, the user of Anaheim Automation products in life support applications assumes all risks of such use and indemnifies Anaheim Automation against all damages.

LIMITED WARRANTY

All Anaheim Automation products are warranted against defects in workmanship, materials and construction, when used under Normal Operating Conditions and when used in accordance with specifications. This warranty shall be in effect for a period of twelve months from the date of purchase or eighteen months from the date of manufacture, whichever comes first. **Warranty provisions may be voided if products are subjected to physical modifications, damage, abuse, or misuse.**

Anaheim Automation will repair or replace at its’ option, any product which has been found to be defective and is within the warranty period, provided that the item is shipped freight prepaid, with previous authorization (RMA#) to Anaheim Automation’s plant in Anaheim, California.

TECHNICAL SUPPORT

If you should require technical support or if you have problems using any of the equipment covered by this manual, please read the manual completely to see if it will answer the questions you have. Be sure to refer to the TROUBLESHOOTING section of this manual. If you need assistance beyond what this manual can provide, contact your Local Distributor where you purchased the unit, or contact the factory direct.

Torque Speed Curves

BLD72 Series with 23L004 and 23L108

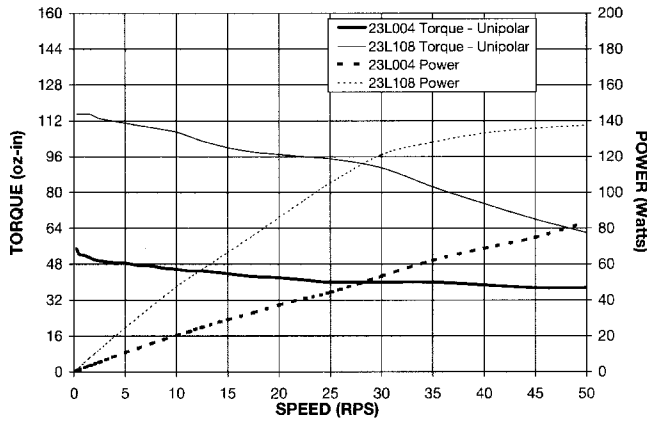

BLD72 Series with 23L210 and 23L310

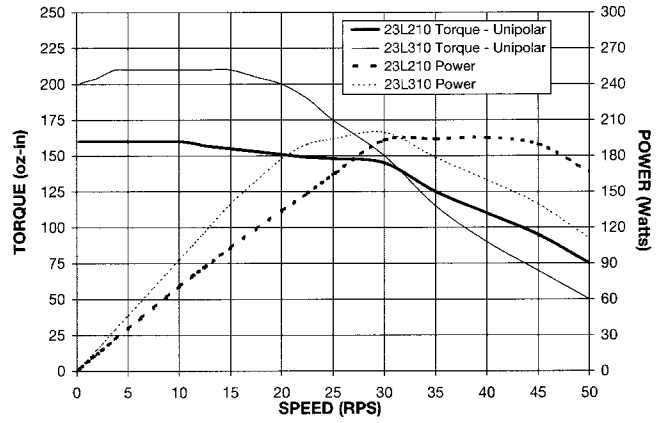

BLD72 Series with 23D309 and 34D109

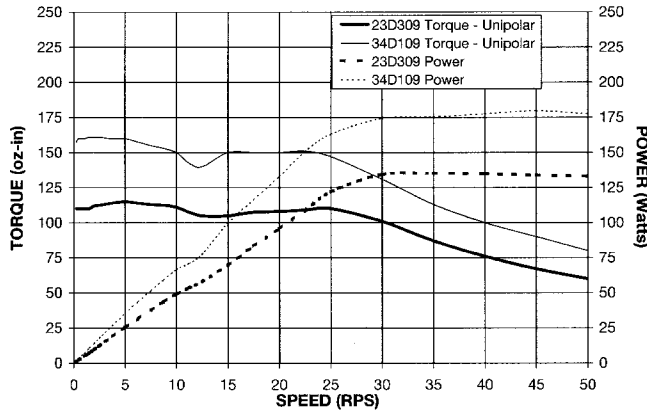

BLD72 Series with 34D213 and 34D314

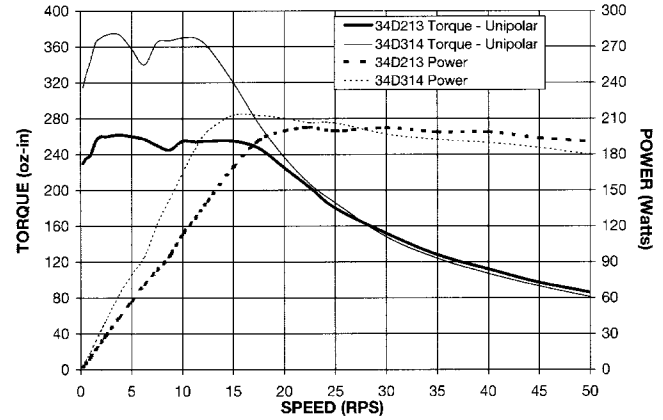

BLD72 Series with 34N112 and 34N214

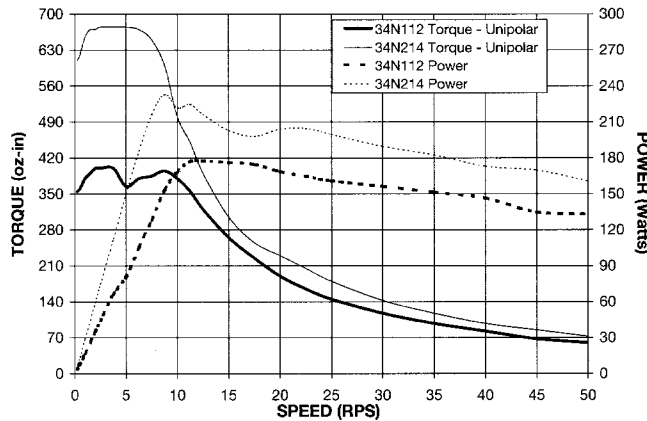

BLD72 Series with 42N214 and 42K214

